

三菱工業用ミシン部品カタログ

MITSUBISHI Industrial Sewing Machine Parts Catalog

Model
DB-130G

目次	INDEX	Page
1. 機 構 図	Total assembly	
2. 本 体 関 係	Arm bed & its accessories	1
3. 天 秤・針 棒 関 係	Thread take-up lever & needle bar mechanism	5
4. 上 軸・豎 軸 関 係	Arm shaft & vertical shaft mechanism	7
5. 送 り 調 節 器 関 係	Stich length regulator mechanism	9
6. 押 エ 関 係	Presser foot mechanism	11
7. 水 平 送 り 軸・上 下 送 り 軸 関 係	Feed rock shaft & feed lifting shaft mechanism	13
8. 下 軸・カ マ 関 係	Rotating hook shaft & rotating hook mechanism	15
9. 給 油 関 係	Lubrication mechanism	17
10. 付 属 品 箱 関 係	Accessory box & its accessories	19
11. 油 槽、ト ン、他 付 属 品 関 係	Oil reservoir & other accessories	21

 三菱電機株式会社

198005

機構図

TOTAL ASSEMBLY

DB-130G

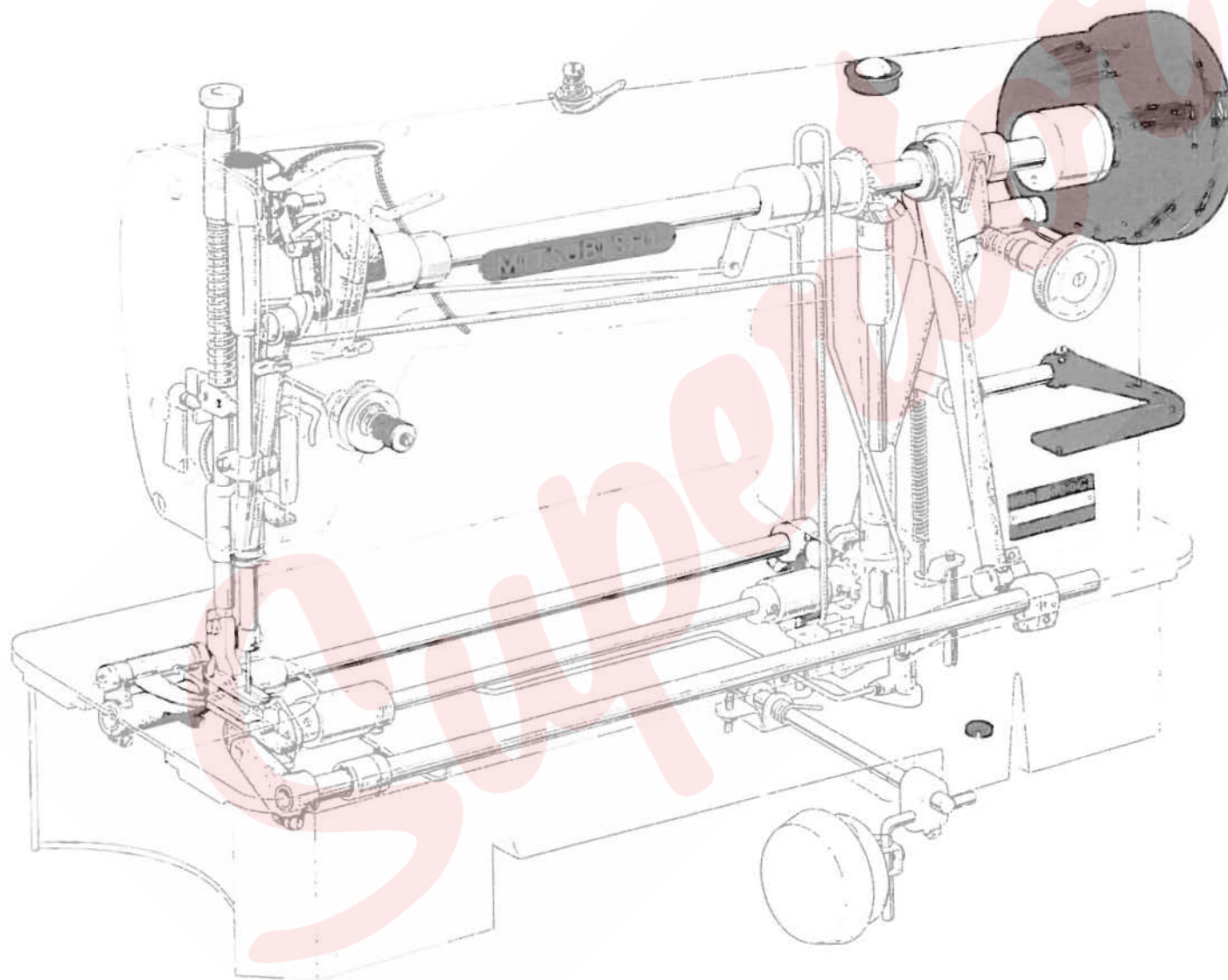

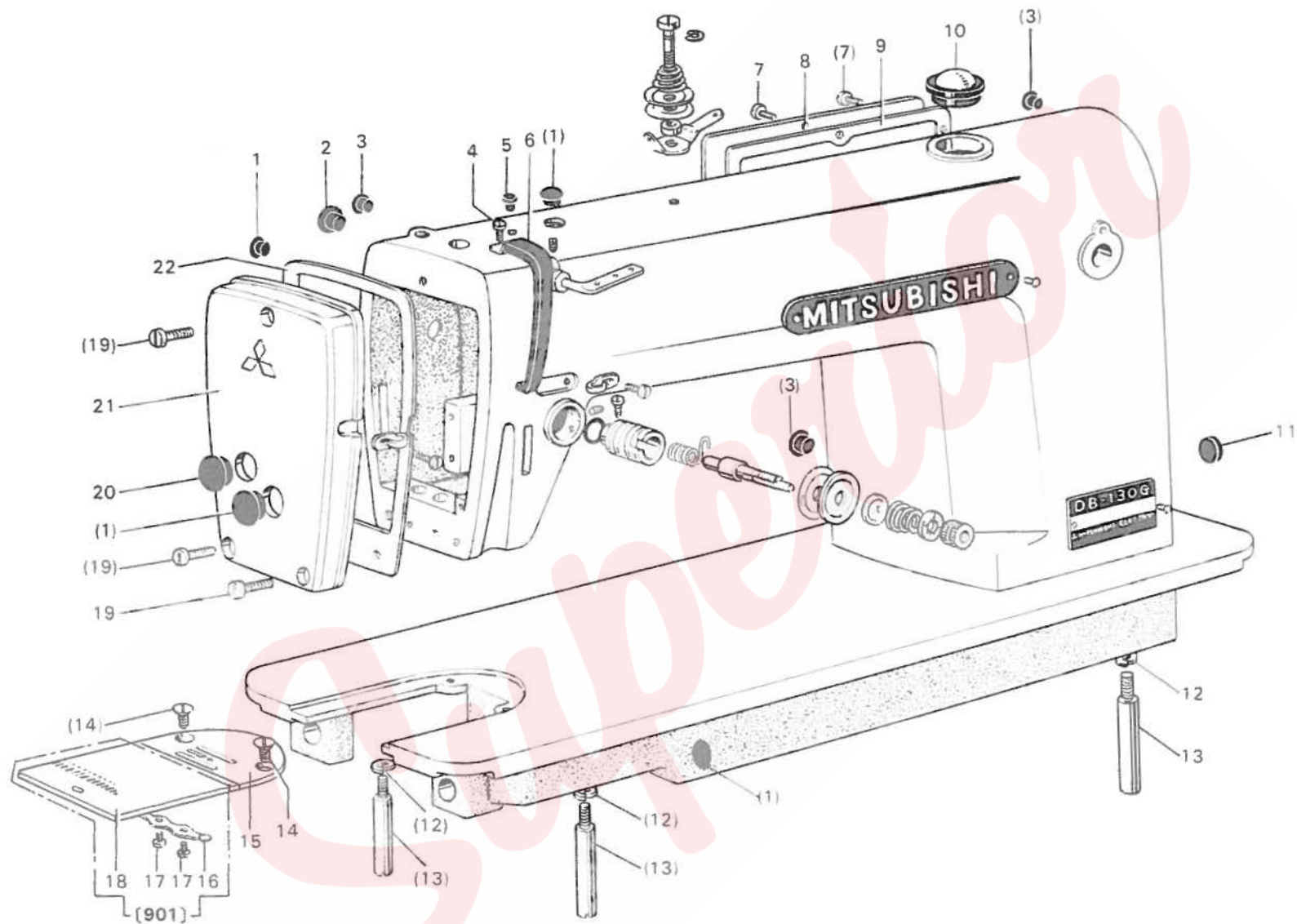

本体関係

ARM BED & ITS ACCESSORIES

Fig. No	部品コード Parts No	資材コード Ref. No.	部 品 名	Description	使用 個数 Amt Req.	共通部品 Common Parts								
						DB130G10	DB130G11	DB130G17	DB130G22	DB130F10	DB130F11	DB130E17	DB130E22	
1	M9 1180 080	W502069H01	ゴム栓 (φ11.8)	Rubber plug (φ11.8)	4									
2	M9 1900 080	W501374H01	ゴム栓 (φ19)	Rubber plug (φ19)	1									
3	M9 0880 080	W501320H01	ゴム栓 (φ8.8)	Rubber plug (φ8.8)	3									
4	M9 1107 002	W500092H01	平ネシ 11/64(40)×5.5	Screw 11/64(40)×5.5	1									
5	M9 0570 080	W502078H01	ゴム栓 (φ5.7)	Rubber plug (φ5.7)	1									
6	MF 10A0 584	W468291H01	天秤カバー	Thread take-up cover	1									
	MF 17B0 584	W458150H01	天秤カバー (2倍カメラ)	Thread take-up cover	1									
7	M9 1101 004	W466810H01	ブラマイネシ 11/64(40)×8	Screw 11/64(40)×8	8									
8	MF 80A0 880	W344943H01	横蓋	Arm side cover	1									
9	MF 80A0 691	W344944H01	ガasket (横蓋)	Gasket for arm side cover	1									
10	MF 20A0 135	P 674006X01	油窓	Oil check window	1									
11	M9 2700 080	W486306H01	ゴム栓 (φ27)	Rubber plug (φ27)	1									
12	M9 0621 053	S 561111H02	ハネ圧金 #6	Spring washer for leg #6	3									
13	MF 10A0 151	W452343H01	脚	Leg	3									
14	M9 1102 011	W500197H01	丸皿ネシ 11/64(40)×7	Screw 11/64(40)×7	2									
	MF 11D0 101	W326261H01	針板 (B1.6)	Needle plate (B1.6)	1									
15	MF 21D1 101	W324529H01	針板 (A1.6)	Needle plate (A1.6)	1									
	MF 26B0 101	W322721H01	針板 (B2.6)7mm	Needle plate (B2.6) 7mm	1									
16	MF 10A0 471	B 419207H01	板ハネ (スヘリ板)	Spring for slide plate	1									
17	M9 0604 002	B 509070H01	平ネシ 3/32(56)×2.2	Screw 3/32(56)×2.2	2									
18	MG 30A0 470	B 419208H02	スヘリ板	Slide plate	1									
901	MF 80E0 470	W461757G02	スヘリ板組	Slide plate complete	1	○	○	○	○					
19	M9 1102 004	W467880H01	ブラマイネシ 11/64(40)×10	Screw 11/64(40)×10	3									
20	M9 5002 080	W472710H01	ゴム栓 (φ19)	Rubber plug (φ19)	1									
21	MF 20A1 830	W331470H02	面板	Face plate	1									
22	MF 70A2 691	W470264H02	ガasket (面板)	Gasket for face plate	1									

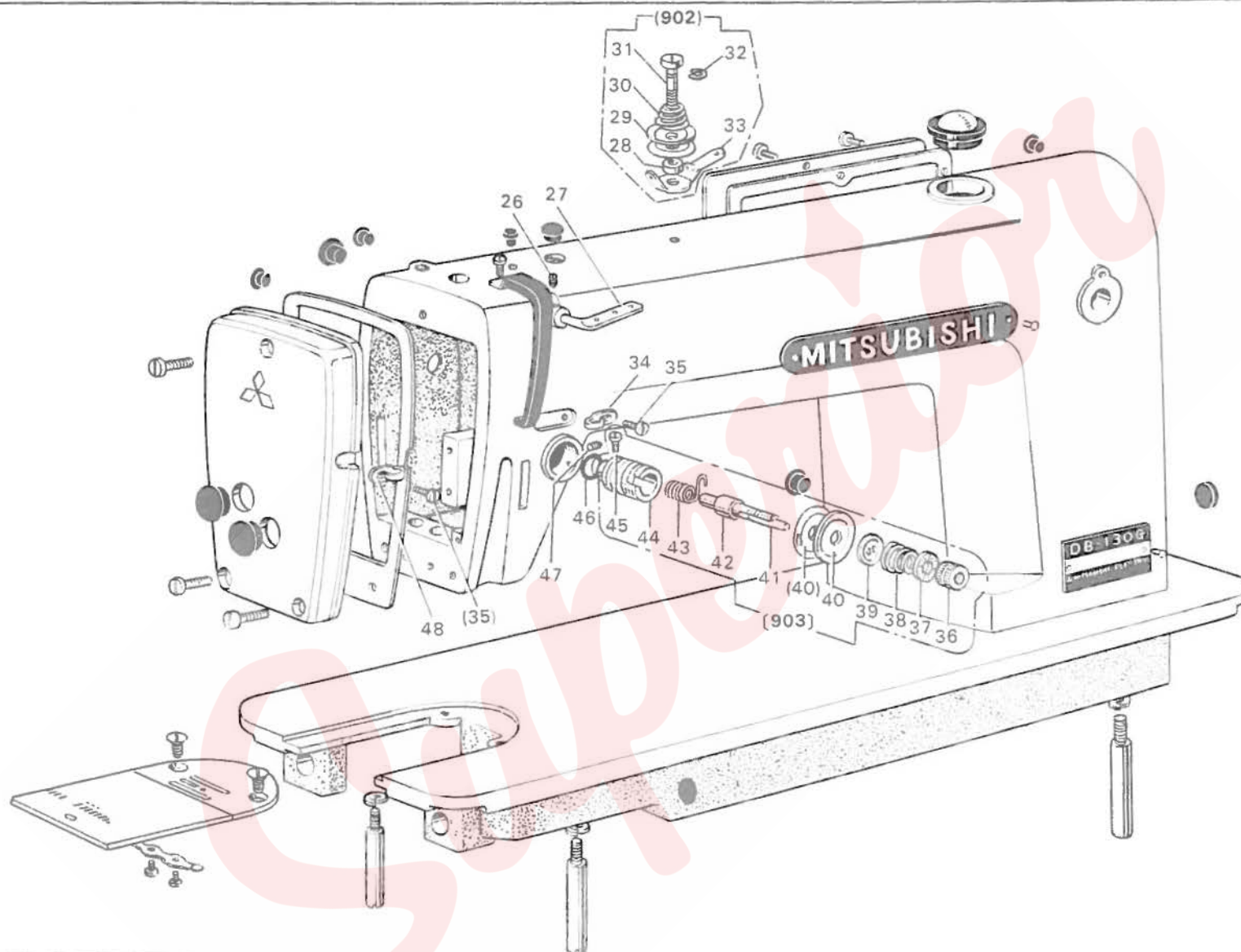

本体関係

ARM BED & ITS ACCESSORIES

Fig No	部品コード Parts. No.	資材コード Ref No.	部 品 名	Description	使用 個数 Amt. Req.	共通部品 Common Parts							
						DB130-G-10	DB-130G-11	DB-130G-12-7	DB-130G-22	DB-130E-10	DB-130E-11	DB-130F-127	DB-130E-22
26	M9 1108 001	B 503846H01	頭ナシ止メネジ 11/64(40)×5.5	Set screw 11/64(40)×5.5	1	○	○	○	○	○	○	○	○
27	MF 10A0 180	B 409034H01	糸 案 内 (上) (ミツ目糸掛)	Three hole thread guide	1	○	○	○	○	○	○	○	○
28	MF 20A0 476	W470268H01	ス ペ ー サ (プリテンション)	Spacer for pre-tension	1	○	○	○	○	○	○	○	○
29	MF 10A1 555	W501636H01	調 子 皿 (プリテンション)	Tension discs for pre-tension	2	○	○	○	○	○	○	○	○
30	MF 20A0 245	W475419H01	円 錐 バ ネ (プリテンション)	Tension spring for pre-tension	1	○	○	○	○	○	○	○	○
31	M9 1104 016	W470267H01	段付丸平ネジ 11/64(40)×16	Screw type tension stud	1	○	○	○	○	○	○	○	○
32	M9 0503 065	S 592411H03	E 形 止 メ 輪 ㊟3	E-type stop ring ㊟3	1	○	○	○	○	○	○	○	○
33	MF 70A0 180	W481446H01	糸 案 内 (プリテンション)	Thread guide for pre-tension	1	○	○	○	○	○	○	○	○
902	MF 70E0 550	W341647G01	プリテンション (組)	Pre-tension complete	1	○	○	○	○	○	○	○	○
34	MF 80A0 181	W483484H01	糸 案 内 (中)	Thread guide for arm center	1	○	○	○	○	○	○	○	○
	MF 83A0 181	W483485H01	糸 案 内 (中) (2倍ガマ)	Thread guide for arm center	1	○	○	○	○	○	○	○	○
35	M9 0909 003	W501901H01	丸 平 ネ ジ 9/64(40)×6	Screw 9/64(40)×6	2	○	○	○	○	○	○	○	○
36	M9 1608 046	W476469H01	調 節 ナ ッ ト (上糸調節器)	Thumb nut for thread tension regulator	1	○	○	○	○	○	○	○	○
37	MT 60A0 802	W476470H01	回 リ 止 メ (上糸調節器)	Thumb nut revolution stopper	1	○	○	○	○	○	○	○	○
38	MN 10A3 245	W461785H01	円 錐 バ ネ (上糸調節器) (標準)	Thread tension spring	1	○	○	○	○	○	○	○	○
	MF 10A0 245	W450071H01	円 錐 バ ネ (上糸調節器) (厚物)	Thread tension spring	1	○	○	○	○	○	○	○	○
39	MM 11A0 556	W477611H01	調 子 皿 押 エ (上糸調節器)	Thread tension releasing discs	1	○	○	○	○	○	○	○	○
40	MF 10A0 555	W444059H01	調 子 皿 (上糸調節器)	Thread tension discs	2	○	○	○	○	○	○	○	○
41	M9 0204 060	B 509216H01	ピ ン (上糸調節器)	Thread tension releasing pin	1	○	○	○	○	○	○	○	○
42	MF 10A0 553	B 419178H01	調 子 棒	Thread tension stud	1	○	○	○	○	○	○	○	○
43	MF 80A1 187	W486372H01	糸 取 リ バ ネ (上糸調節器) (標準)	Thread take-up spring	1	○	○	○	○	○	○	○	○
	MF 83A1 187	W486372H02	糸 取 リ バ ネ (上糸調節器) (厚物)	Thread take-up spring	1	○	○	○	○	○	○	○	○
44		W453140H01	ブ ッ シ ュ (上糸調節器)	Thread tension regulating bushing	1	○	○	○	○	○	○	○	○
45	M9 0901 002	W500741H01	平 ネ ジ 9/64(40)×4	Set screw 9/64(40)×4	1	○	○	○	○	○	○	○	○
46	M9 1501 085	P 648001X01	オ リ ン グ S15	Rubber ring S15	1	○	○	○	○	○	○	○	○
47	M9 1508 001	B 509088H01	頭ナシ止メネジ 15/64(28)×8	Set screw 15/64(28)×8	1	○	○	○	○	○	○	○	○
48	MF 10A0 181	W452151H01	糸 案 内 (面板)	Thread guide for face plate	1	○	○	○	○	○	○	○	○
	MF 17B0 181	W470968H01	糸 案 内 (面板) (2倍ガマ)	Thread guide for face plate	1	○	○	○	○	○	○	○	○
903	MF 80E0 210	W346065G01	上 糸 調 節 器 (組) (標準)	Thread tension regulator complete	1	○	○	○	○	○	○	○	○
	MF 82E0 210	W346065G02	上 糸 調 節 器 (組) (厚物)	Thread tension regulator complete	1	○	○	○	○	○	○	○	○

THREAD TAKE-UP LEVER & NEEDLE BAR MECHANISM

DB-130G

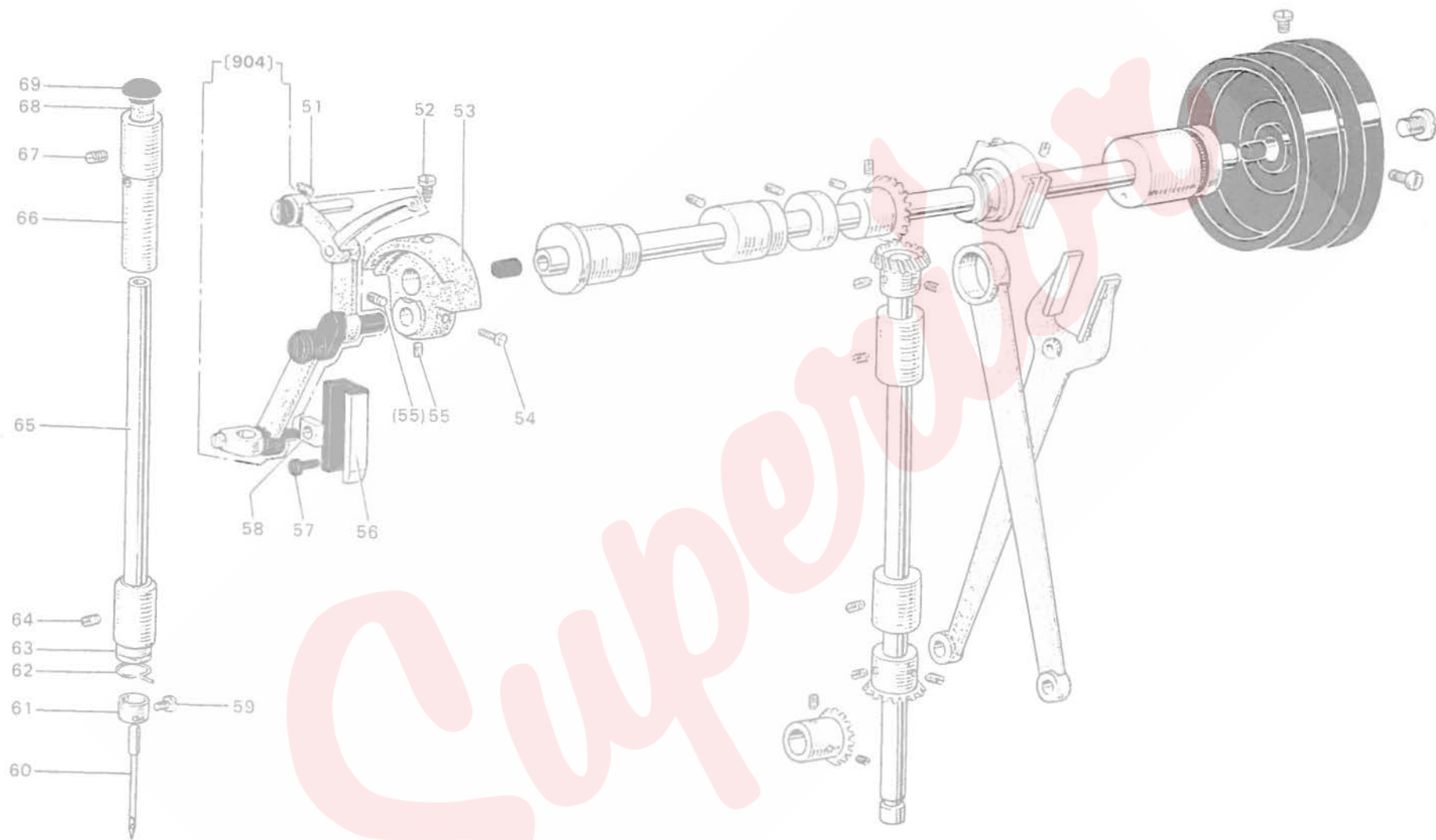

天秤・針棒関係

THREAD TAKE-UP LEVER & NEEDLE BAR MECHANISM

Fig No	部品コード Parts No	資材コード Ref. No.	部 品 名	Description	使用 個数 Amt. Req.	共通部品 Common Parts									
						DB-130G-10	DB-130G-11	DB-130G-12-7	DB-130G-22	DB-130E-10	DB-130E-11	DB-130E-12-7	DB-130E-22		
904	MF 80E0 580	W346054G01	天 秤 針 ク (組) (標準)	Thread take-up lever complete	1	○	○								
	MF 82E0 580	W346054G02	天 秤 針 ク (組) (厚物)	Thread take-up lever complete	1			○							
	MF 83E0 580	W346054G03	天 秤 針 ク (組) (2倍ガマ)	Thread take-up lever complete	1				○						
51	M9 1516 001	W500006H01	頭ナシ止メネジ 15/64(28)×13	Set screw 15/64(28)×13	2	○	○	○	○	○	○	○	○	○	○
52	M9 1802 006	B 503851H01	棒先平ネジ 9/32(28)×14	Set screw 9/32(28)×14	1	○	○	○	○	○	○	○	○	○	○
53	MF 80E0 383	W484898H01	ク ラ ン ク (標準)	Crank	1	○	○	○							
	MF 81E0 383	W486325H01	ク ラ ン ク (薄物)	Crank	1		○								
54	M9 1801 002	W500306H01	平 ネ ジ 9/32(28)×13	Set screw 9/32(28)×13	1	○	○	○	○	○	○	○	○	○	○
55	M9 1608 001	B 504016H02	頭ナシ止メネジ 1/4(40)×6	Set screw 1/4(40)×6	2	○	○	○	○						
56	MF 80A0 662	W444056H02	針棒クランクガイド (案内台)	Needle bar connecting link guide	1	○	○	○	○	○	○	○	○	○	○
57	M9 1110 002	W500294H01	平 ネ ジ 11/64(40)×8	Screw 11/64(40)×8	2	○	○	○	○	○	○	○	○	○	○
58	MF 10A0 325	W443934H01	角 駒 (針棒ダキ)	Square block	1	○	○	○	○	○	○	○	○	○	○
59	M9 0815 002	W484210H01	平 ネ ジ 1/8(44)×4.5	Needle clamp screw 1/8(44)×4.5	1	○	○	○	○						
	MF 70A0 128	S 970010H01	ミ シ ン 針 DB×1-2-14	Needle DB×1-2-14	1	○			○						
60	MF 21D0 128	S 970001H01	ミ シ ン 針 DA×1≠11	Needle DA×1≠11	1		○			○					
	MF 83A0 128	S 970002H03	ミ シ ン 針 DB×1≠22	Needle DB×1≠22	1			○			○				
61	MF 80A1 181	W486318H01	糸 案 内 (糸カケ) (針棒)	Thread guide for needle bar	1	○	○	○	○	○	○	○	○	○	○
62	MF 10A1 181	W502073H01	糸 案 内 (針棒メタル下)	Thread guide for needle bar bushig	1	○	○	○	○	○	○	○	○	○	○
63	MF 10A0 664	W450055H01	針 棒 メ タ ル (下) (標準)	Needle bar bushing (lower)	1	○	○	○	○	○	○				
	MF 17B0 664	W457585H01	針 棒 メ タ ル (下) (2倍ガマ)	Needle bar bushing (lower)	1			○				○			
64	M9 1102 001	W500489H01	頭ナシ止メネジ 11/64(40)×2.7	Set screw 11/64(40)×2.7	1	○	○	○	○	○	○	○	○	○	○
65	MF 80A0 660	W486319H01	針 棒 (標準)	Needle bar	1	○									
	MF 81A0 660	W486321H01	針 棒 (薄物)	Needle bar	1		○								
	MF 82A0 660	W486322H01	針 棒 (厚物)	Needle bar	1			○							
	MF 83A0 660	W486310H01	針 棒 (2倍ガマ)	Needle bar	1				○						
66	MF 70A0 663	W481449H01	針 棒 メ タ ル (上)	Needle bar bushing (upper)	1	○	○	○	○	○	○	○	○	○	○
67	M9 1503 001	B 508971H01	頭ナシ止メネジ 15/64(28)×4.5	Set screw 15/64(28)×4.5	1	○	○	○	○	○	○	○	○	○	○
68	MF 10A2 740	W500003H01	フ ェ ル ト (針棒メタル上)	Felt for Needle bar bushing (upper)	1	○	○	○	○						
69	M9 0881 080	W502944H01	ゴ ム 栓 φ8.8 (針棒メタル上)	Rubber plug φ8.8	1	○	○	○	○						

ARM SHAFT & VERTICAL SHAFT MECHANISM

DB-130G

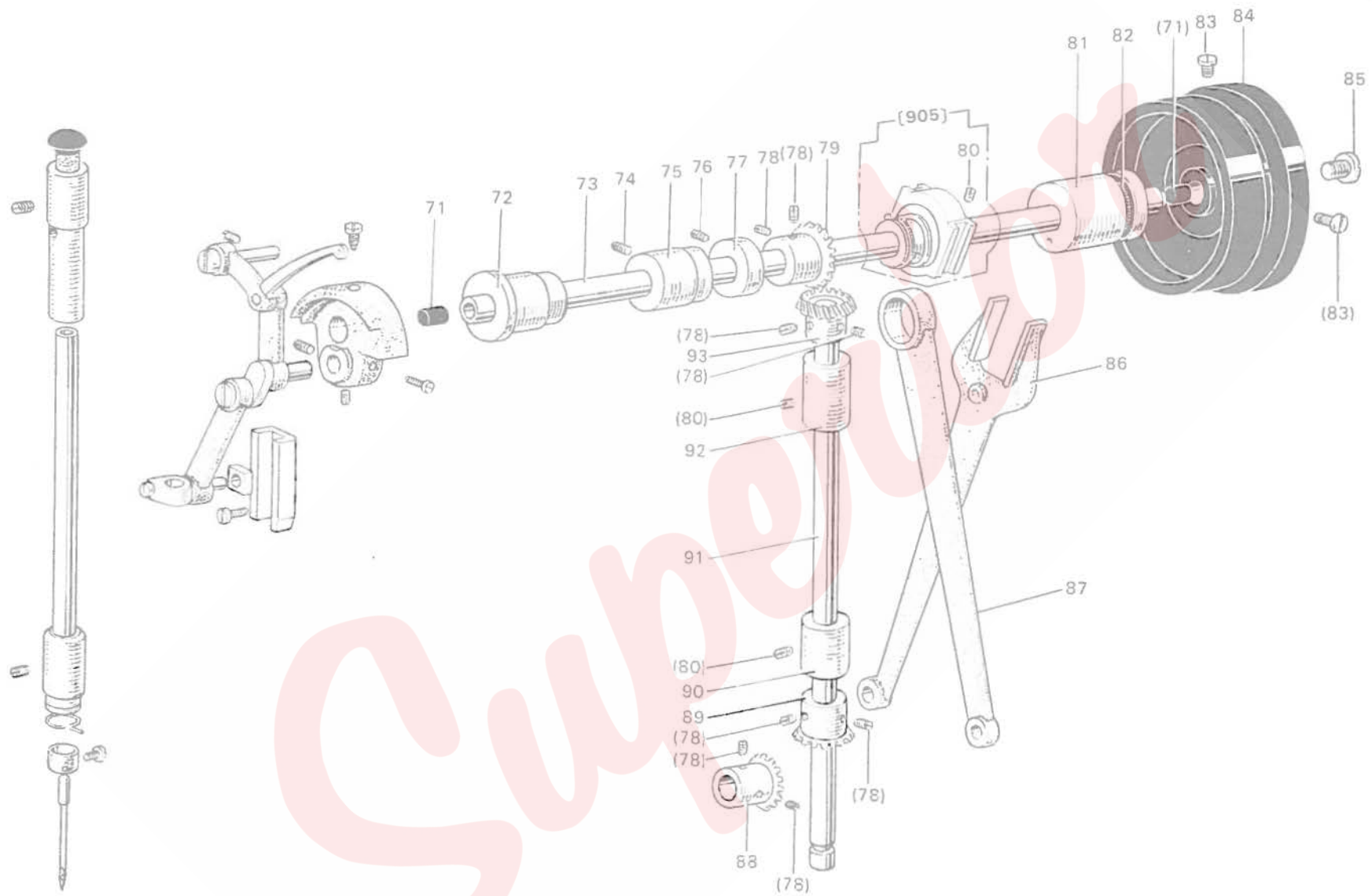

上軸・豎軸関係

ARM SHAFT & VERTICAL SHAFT MECHANISM

Fig No	部品コード Parts No	資材コード Ref No	部 品 名	Description	使用 個数 Amt Req	共通部品 Common Parts											
						DR 130G 10	DB 130G 11	DB 130G 12/7	DB 130G 22	DR 130E 10	DB 130E 11	DB 130E 12/7	DB 130E 22				
71	M9 0740 080	W478175H01	ゴム栓 (上軸) $\phi 7.4 \times 10$	Rubber plug for arm shaft $\phi 7.4 \times 10$	2												
72	MF 80A0 232	W486300H01	上軸メタル (左)	Bushing for arm shaft (left)	1												
73	MF 80A0 230	W346047H01	上軸	Arm shaft	1												
74	M9 1516 001	W500006H01	頭ナシ止メネジ $15/64(28) \times 15$	Set screw $15/64(28) \times 15$	1												
75	MF 70A0 234	W481452H01	上軸メタル (中)	Bushing for arm shaft (middle)	1												
76	M9 1602 001	W500036H01	頭ナシ止メネジ $1/4(40) \times 4$	Set screw $1/4(40) \times 4$	2												
77	MF 70A0 352	W476422H01	カラ (上軸)	Collar for arm shaft	1												
78	M9 1606 001	P 911000X01	頭ナシ止メネジ $1/4(40) \times 7$	Set screw $1/4(40) \times 7$	8												
79	MF 10A0 331	P 611003X01	傘歯車 (上軸)	Bevel gear for arm shaft	1												
905	MF 70E0 280	W481451G01	偏心輪 (組) (送りカム)	Feed cam complete	1												
80	M9 1513 001	B 509060H01	頭ナシ止メネジ $15/64(28) \times 10.5$	Set screw $15/64(28) \times 10.5$	3												
81	MF 70A0 233	W481413H01	上軸メタル (右)	Bushing for arm shaft (right)	1												
82	M9 1473 086	W481476H01	オイルシール (上軸右)	Oil seal for arm shaft (right)	1												
83	M9 1502 002	W500509H01	平ネジ $15/64(28) \times 12$	Set screw $15/64(28) \times 12$	2												
84	MF 10A0 682	W453500H01	ハズミ車	Balance wheel	1												
85	M9 2201 003	W461726H01	丸平ネジ $11/32(28) \times 10$	Screw $11/32(28) \times 10$	1												
86	MF 10A0 744	W320448H01	フタ又	Feed forked connecting rod	1												
	MF 26B0 744	W327698H01	フタ又 (7mm)	Feed forked connecting rod (7mm feed)	1												
87	MF 70A0 384	W450961H01	クランクロッド (連接桿)	Crank rod for feed lifting rock shaft	1												
88	MF 10A0 332	P 611002X01	傘歯車 (下軸)	Bevel gear for hook shaft	1												
89	MF 10A0 334	P 611001X01	傘歯車 (豎軸下)	Bevel gear for vertical shaft (lower)	1												
90	MF 70A0 522	W481418H02	豎軸メタル (下)	Bushing for vertical shaft (lower)	1												
	MF 74B0 522	W481696H01	豎軸メタル (下) (2倍カム)	Bushing for vertical shaft (lower)	1												
91	MF 10A0 520	W450080H01	豎軸	Vertical shaft	1												
92	MF 70A0 521	W481418H01	豎軸メタル (上)	Bushing for vertical shaft (upper)	1												
93	MF 10A0 333	P 611000X01	傘歯車 (豎軸上)	Bevel gear for vertical shaft (upper)	1												

STITCH LENGTH REGULATOR MECHANISM

DB-130G

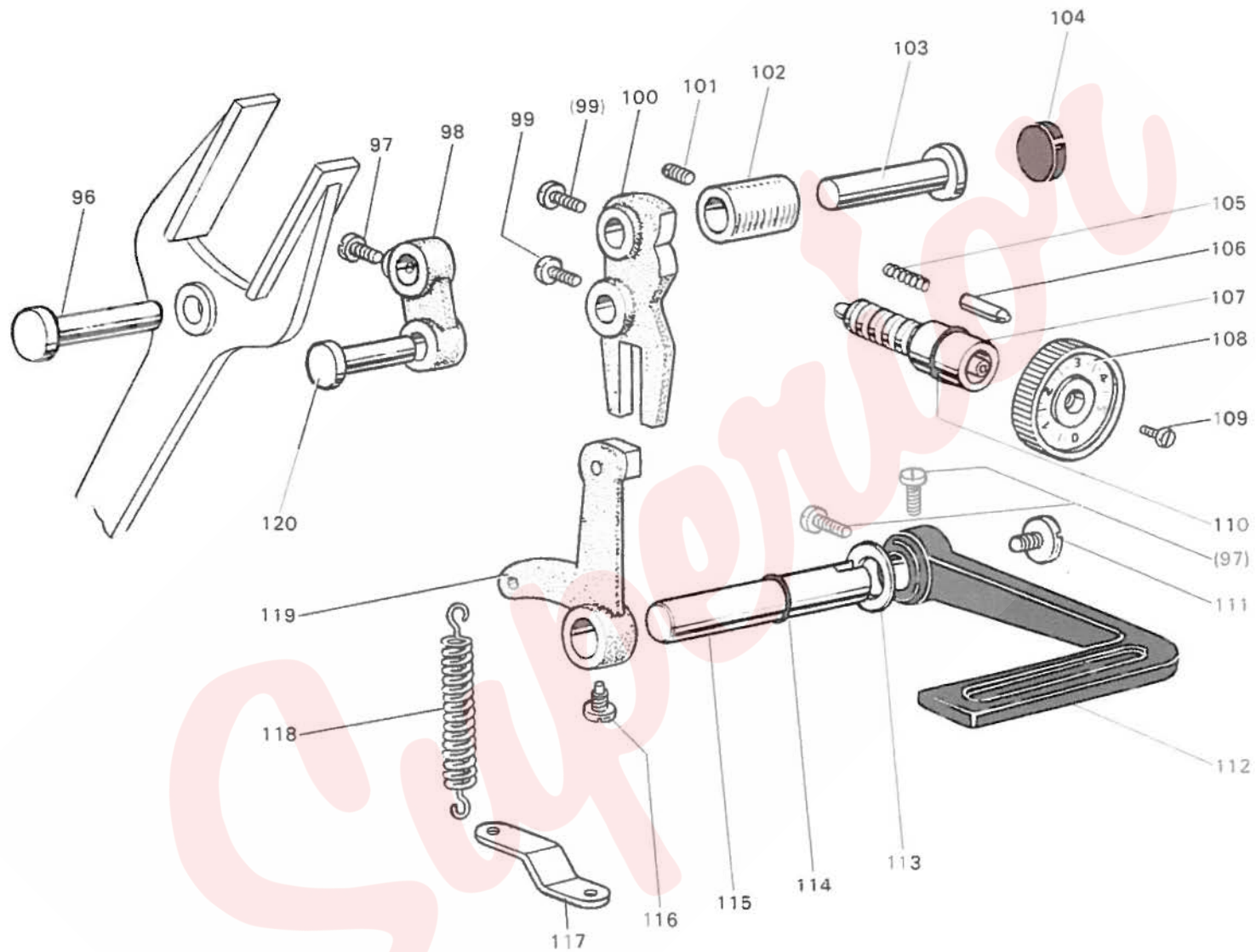

送り調節器関係

STITCH LENGTH REGULATOR MECHANISM

Fig No	部品コード Parts No	資材コード Ref. No.	部 品 名 Description	使用 個数 Amt Req	共通部品 Common Parts													
					DB130G10	DB130G11	DB130G12	DB130G22	DB130E10	DB130E11	DB130E17	DB130E22						
96	M9 0718 063	W481425H01	段付キ軸 (フタ又) φ7.2×19	Set pin φ7.2×19	1													
97	M9 1501 002	W502945H01	平ネジ 15/64(28)×8.5	Screw 15/64(28)×8.5	3													
98	MF 70A0 153	W481677H01	連結桿 (案内テコ継ぎ)	Feed connecting link	1													
99	M9 1504 002	B 508963H01	平ネジ 15/64(28)×10	Screw 15/64(28)×10	2													
100	MF 80A0 152	W447221H02	案内テコ	Feed regulator	1													
	MF 82A1 152	W336661H02	案内テコ (7mm)	Feed regulator (7mm feed)	1													
101	M9 1513 001	B 509060H01	調節止メネジ 15/64(28)×11	Set screw 15/64(28)×11	1													
102	MF 70A0 750	W479396H02	フック (案内テコ)	Bushing for feed regulator	1													
103	M9 0904 063	W479395H01	段付キ軸 (案内テコ)	Set pin	1													
104	M9 2001 080	W479394H01	ゴム栓 (案内テコ) φ20×4	Rubber plug φ20×4	1													
105	MF 10A2 572	B 509164H01	ソル卷バネ (戻り止メ)	Spring for stopper pin	1													
106	MF 80A0 852	W481688H01	戻り止メ (縫目加減ダイヤル)	Stopper pin for stitch length regulator	1													
107	MF 80A0 641	W481899H01	ネジ棒	Screw bar	1													
	MF 10A0 631	W331475H01	ダイヤル (縫目加減0-5)	Dial for stitch length regulator (0-5)	1													
108	MF 11D0 631	W331486H01	ダイヤル (縫目加減0-4)	Dial for stitch length regulator (0-4)	1													
	MF 26B0 631	W331487H01	ダイヤル (縫目加減0-7)	Dial for stitch length regulator (0-7)	1													
109	M9 1209 002	B 503887H01	平ネジ 3/16(28)×8	Screw 3/16(28)×8	1													
110	M9 1000 085	S 648001H06	オリング φ10 (ネジ棒)	O ring φ10 for screw bar	1													
111	M9 1207 003	B 509288H01	丸平ネジ 3/16(28)×6.5	Screw 3/16(28)×6.5	1													
112	MF 80A0 632	W346067H01	レバー (縫目加減)	Reverse sewing lever	1													
113	M9 5003 053	B 503895H01	バネ座全 (レバー)	Spring washer	1													
114	M9 0600 085	S 648001H04	オリング φ6 (軸)	O ring for reverse sewing lever shaft	1													
115	MF 10A0 633	W450088H01	軸 (縫目加減)	Shaft for reverse sewing lever	1													
116	M9 1501 007	B 509256H01	棒先丸平ネジ 15/64(28)×14.5	Screw 15/64(28)×14.5	1													
117	MF 10A0 708	W501378H01	ハネ止メ板	Bracket for spring	1													
118	MF 10A0 572	W447225H01	ソル卷バネ (縫目加減)	Spring for reverse sewing crank	1													
119	MF 40E1 635	W462614G03	縫目加減腕 (コロ・ネジ付キ) 組	Reverse sewing crank complete	1													
120	M9 0905 063	W501377H01	ピン (案内テコ継ぎ)	Set pin for feed connecting link	1													

PRESSER FOOT MECHANISM

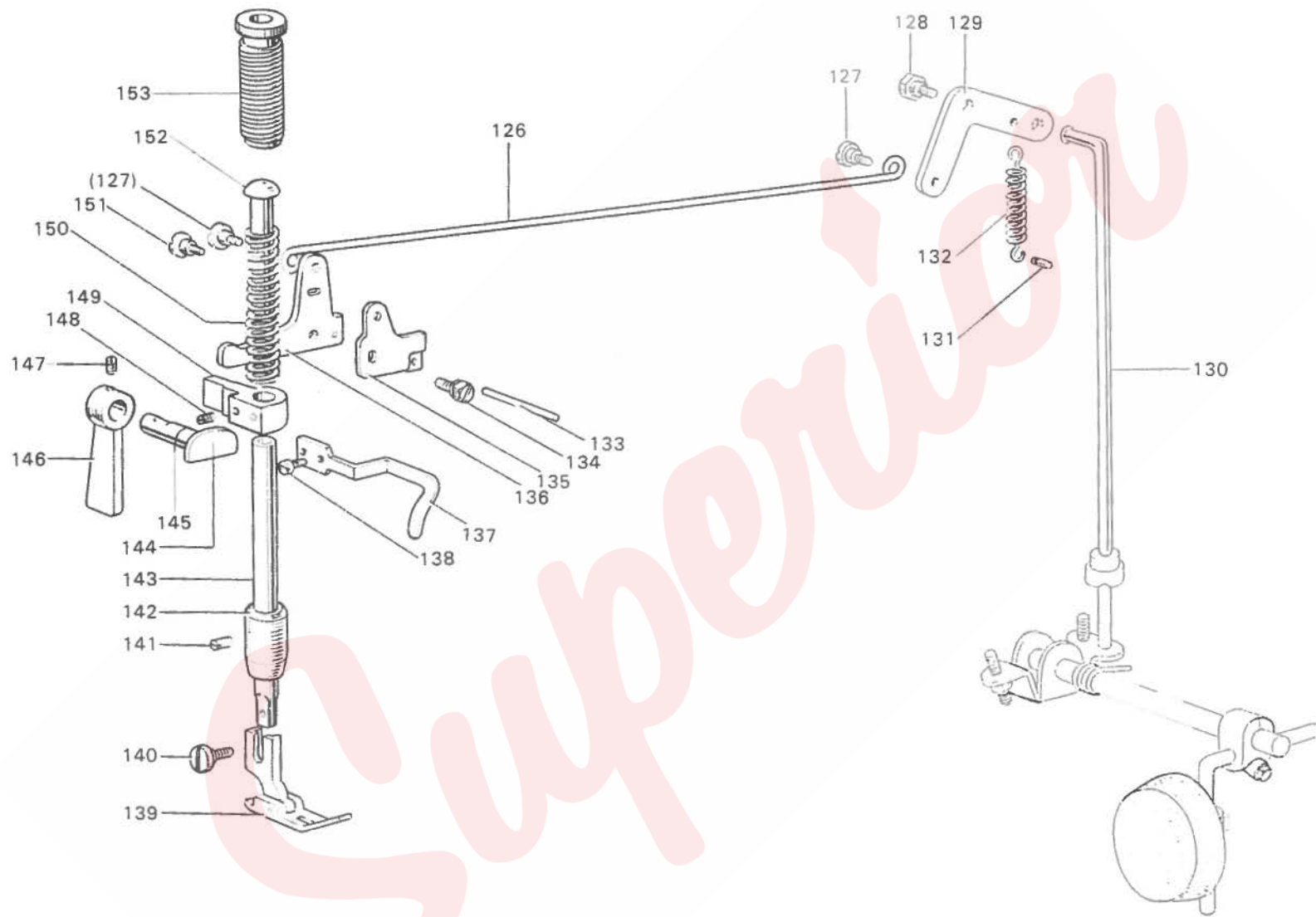

押工関係

PRESSER FOOT MECHANISM

Fig No	部品コード Parts No	資材コード Ref No	部 品 名	Description	使用 個数 Amt Req	共通部品 Common Parts								
						DB 130G 10	DB 130G 11	DB 130G 12 7	DB 130G 22	DB 130E 10	DB 130E 11	DB 130E 22	DB 130E 22	
126	MF 70A0 738	W481477H01	引 棒 (押工上ゲ)	Knee lifter rod	1									
127	M9 1219 015	W481460H01	段 付 平 ネジ 3/16(28)×6.7	Hinged screw 3/16(28)×6.7	2									
128	M9 1503 031	W481459H01	段 付 ボルト (押工上ゲレバー)	Bolt for knee lifter lever	1									
129	MF 70A1 950	W481458H01	押工上ゲレバー (右)	Knee lifter lever (right)	1									
130	MF 70A0 511	W481456H01	操 作 棒 (突上ゲ棒)	Knee lifter connecting rod	1									
131	M9 0506 060	P 587011X01	溝 付 キ ビ ン (BX形) φ5×24	Pin for spring φ5×24	1									
132	MF 70A0 572	W481478H01	ツル巻バネ (押工上ゲレバー)	Spring for knee lifter lever	1									
133	M9 041 906	W502957H05	ピ ン (押工上ゲレバー) φ4×37.5	Tension releasing pin φ4×37.5	1									
134	M9 1504 031	W481459H02	段 付 ボルト 15/64(28)×13.5	Bolt 15/64(28)×13.5	1									
135	MF 70A0 350	W484212H01	糸ユルメカム	Tension releasing cam	1									
136	MF 70A2 950	W481457H02	押工上ゲレバー (左)	Knee lifter lever (left)	1									
137	MF 10A0 216	W502083H01	上 糸 案内	Thread guide	1									
138	M9 1107 002	W500092H01	平 ネ ジ 11/64(40)×5.5	Screw 11/64(40)×5.5	1									
139	MF 10A0 105	W450580G01	押 エ (標準)	Presser foot	1									
	MF 21D0 105	W472730G01	押 エ (薄物)	Presser foot	1									
	MF 12B0 105	W331472G01	押 エ (厚物)	Presser foot	1									
140	M9 0939 002	W464016H02	平 ネ ジ 9/64(40)×11	Screw 9/64(40)×11	1									
141	M9 1102 001	W500489H01	頭ナシ止メネジ 11/64(40)×2.7	Set screw 11/64(40)×2.7	1									
142	MF 10A0 267	W502081H01	メ タ ル (押工棒)	Bushing for presser bar	1									
143	MF 10A0 262	W502079H01	押 エ 棒 (標準)	Presser bar	1									
	MF 11D0 262	W502943H01	押 エ 棒 (厚物)	Presser bar	1									
144	MF 80A0 253	W487032H01	押工上ゲカム	Presser bar lifting cam	1									
145	M9 0800 086	P 625011X01	オイルシール (押工上ゲカム)	Oil seal for presser bar lifting cam	1									
146	MF 80A0 252	W486373H01	押 工 上 ゲ	Presser bar lifter	1									
147	M9 1109 001	W500985H01	頭ナシ止メネジ 11/64(40)×6.6	Set screw 11/64(40)×6.6	1									
148	M9 1508 001	B 509088H01	頭ナシ止メネジ 15/64(28)×8	Set screw 15/64(28)×8	1									
149	MF 70A1 265	W481461H02	押 工 棒 タキ	Presser bar lifting bracket	1									
150	MF 10A0 259	W502444H01	押 エ バ ネ (標準)	Presser spring	1									
	MF 12B0 259	W502441H01	押 エ ハ ネ (厚物)	Presser spring	1									
151	M9 1118 002	B 509061H01	平 ネ ジ 11/64(40)×10	Screw 11/64(40)×10	1									
152	MF 20A0 703	W475491H01	案 内 棒 (押工バネ)	Presser bar guide	1									
153	M9 3209 035	W481436H01	ツ マ ミ ネ ジ (押工調節) 1/2(28)×6.3	Thumb screw for presser regulator 1/2(28)×6.3	1									

FEED ROCK SHAFT & FEED LIFTING SHAFT MECHANISM

DB-130G

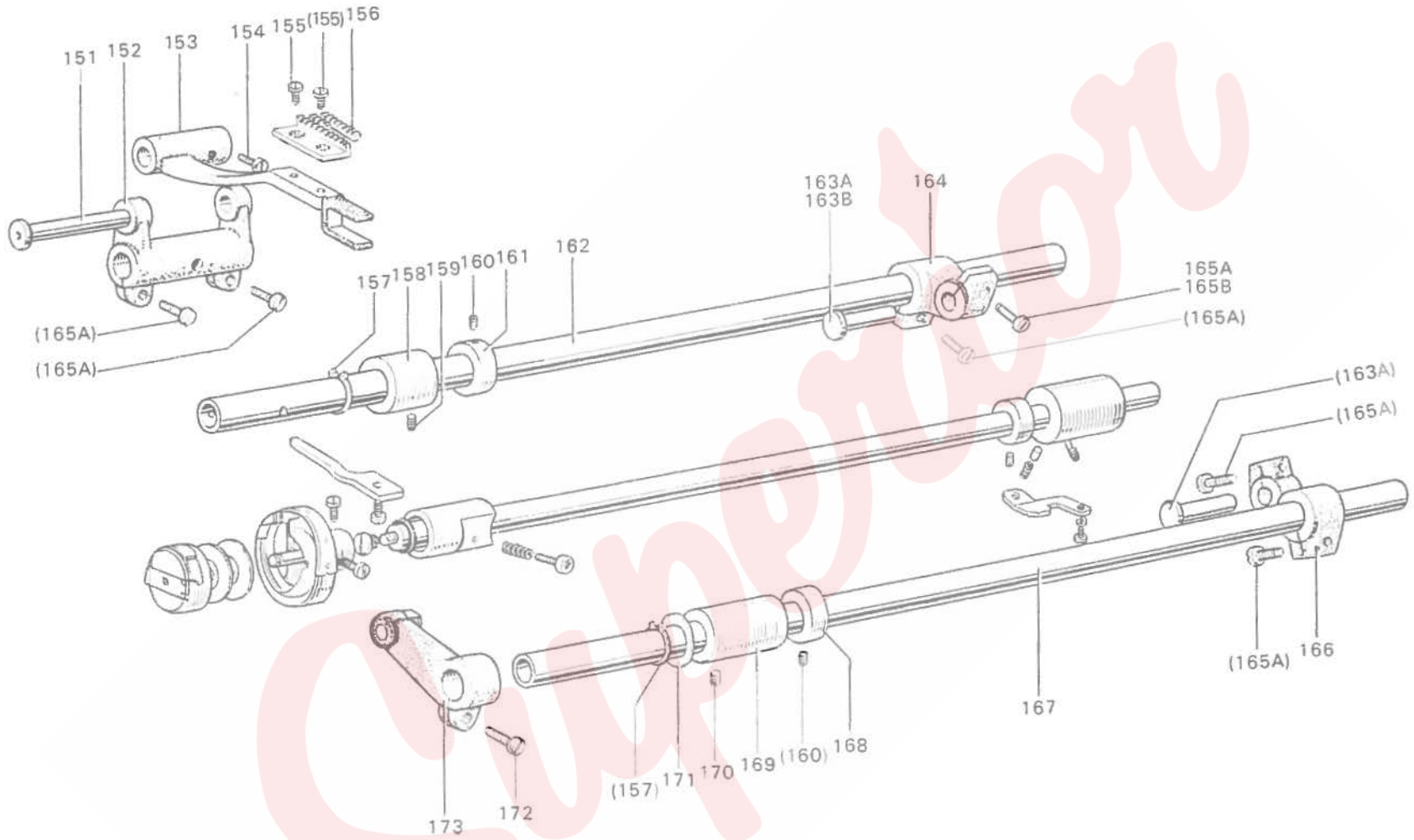

水平送り軸・上下送り軸関係

FEED ROCK SHAFT & FEED LIFTING SHAFT MECHANISM

Fig. No.	部品コード Parts. No	資材コード Ref. No.	部 品 名	Description	使用 個数 Amt. Req	共通部品 Common Parts								
						DB-130G-10	DB-130G-11	DB-130G-12-7	DB-130G-22	DB-130E-10	DB-130E-11	DB-130E-12-7	DB-130E-22	
151	MF 70A0 283	W481422H01	軸 (送り台支工)	Shaft for feed bar	1									
152	MF 70A0 278	W481421H01	送 り 腕 (水平左)	Feed rock shaft crank (left)	1									
153	MF 70A1 281	W484831H01	送 り 台	Feed bar	1									
154	M9 1103 002	B 509062H01	平 ネ ジ 11/64(40)×5	Screw 11/64(40)×5	1									
155	M9 0806 002	B 508857H01	平 ネ ジ 1/8(44)×6	Screw 1/8(44)×6	2									
156	MF 10A0 104	W462604H01	送 り (標準3枚歯)	Feed dog	1									
	MF 11D0 104	W457555H01	送 り (薄物4枚歯)	Feed dog	1									
157	M9 0315 065	S 591411H15	C 形 止 メ 輪 (軸用15)	C-type stop ring	2									
158	MF 70A1 286	W481475H01	水平送り軸メタル (左)	Bushing for feed rock shaft (left)	1									
159	M9 1503 001	B 508971H01	頭ナシ止メネジ 15/64(28)×4.5	Set screw 15/64(28)×4.5	1									
160	M9 1602 001	W500036H01	頭ナシ止メネジ 1/4(40)×4	Set screw 1/4(40)×4	4									
161	MF 80A0 352	W482357H01	カ ラ ー	Collar	1									
162	MF 70A0 491	W481420H01	水 平 送 り 軸	Feed rock shaft	1									
163A	M9 0904 060	W502476H02	ピ ン (ツバツキ軸) φ9.53×21	Pin for feed rock shaft crank (right)	2									
163B	M9 0906 060	W486307H01	ピ ン (ツバツキ軸) φ9.53×21	Pin for feed rock shaft crank (right)	1									
164	MF 70A0 279	W481473H01	送 り 腕 (水平右)	Feed rock shaft crank (right)	1									
	MF 83A0 279	W486308H01	送 り 腕 (水平右)	Feed rock shaft crank (right)	1									
165A	M9 1204 003	B 508978H01	丸 平 ネ ジ 3/16(28)×12	Screw 3/16(28)×12	6									
165B	M9 1515 002	B 508963H02	平 ネ ジ 15/64(28)×10	Screw 15/64(28)×10	1									
166	MF 80A0 277	W486374H01	上 下 送 り 腕 (右)	Feed lifting rock shaft crank (right)	1									
167	MF 70A0 460	W481673H01	上 下 送 り 軸	Feed lifting rock shaft	1									
168	MF 70A0 352	W476422H01	カ ラ ー	Collar for feed lifting rock shaft	1									
169	MF 70A0 286	W481663H01	上下送り軸メタル (左)	Bushing for feed lifting rock shaft (left)	1									
170	M9 1513 001	B 509060H01	頭ナシ止メネジ 15/64(28)×10.5	Set screw 15/64(28)×10.5	1									
171	M9 1502 050	W481674H01	座 金	Washer	1									
172	M9 1112 002	W501889H01	平 ネ ジ 11/64(40)×12	Screw 11/64(40)×12	1									
173	MF 70E0 276	W484828G01	腕 (組) (送り腕上下左)	Crank complete for feed lifting rock shaft	1									

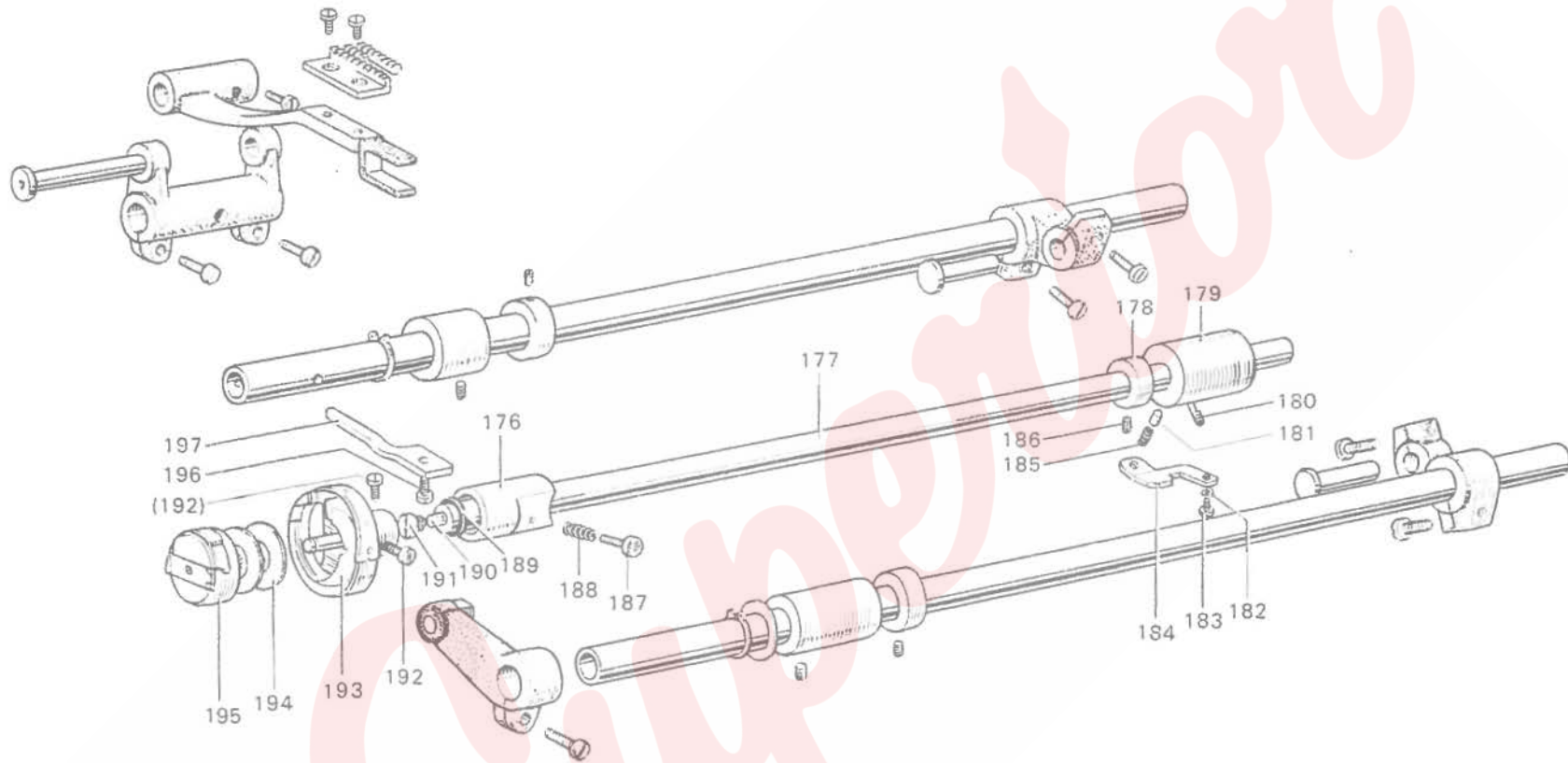

下軸・カマ関係

ROTATING HOOK SHAFT & ROTATING HOOK MECHANISM

Fig. No.	部品コード Parts No.	資材コード Ref No.	部 品 名	Description	使用 個数 Amt. Req.	共通部品 Common Parts									
						DB-130G-10	DB-130E-11	DB-130G-12-7	DB-130G-22	DB-130E-10	DB-130E-11	DB-130E-12-7	DB-130E-22		
176	MF 80A0 451	W346051H01	下軸メタル(左)	Bushing for hook shaft (left)	1										
177	MF 80A0 450	W486311H01	下 軸 標準	Rotating hook shaft	1										
	MF 83A0 450	W486311H02	下 軸 (2倍ガマ)	Rotating hook shaft	1										
178	MF 10A0 352	B 422844H01	カ ラ ー (下軸)	Collar for hook shaft	1										
179	MF 80A0 452	W486309H01	下軸メタル(右)	Bushing for hook shaft (right)	1										
180	MF 80A0 688	W486304H01	ハ イ プ	Pipe for hook shaft bushing	1										
181	M9 5008 063	W486305H01	プランジャー 特殊ピン	Plunger	1										
182	M9 0601 053	S 561121H05	バネ座全	Spring washer	1										
183	M9 1515 002	B 508963H02	平ネジ 15 64(28)×10	Screw 15 64(28)×10	1										
184	MF 80A0 154	W486312H01	案内板	Guide plate	1										
	MF 83A0 154	W486312H02	案内板 (2倍カマ)	Guide plate	1										
185	MF 80A0 572	W486303H01	ノル巻バネ	Spring	1										
186	M9 1503 001	B 508971H01	頭ナシ止メネジ 15 64(28)×4.5	Set screw 15 64(28)×4.5	2										
187	M9 1506 030	W486327H01	特殊ネジ (油調節)	Oil adjusting screw	1										
188	MF 80A1 572	W486330H01	ツル巻バネ (油調節)	Spring for oil adjuster	1										
189	M9 0803 086	P 625002X01	オイルシール (下軸)	Oil seal for rotating hook shaft	1										
190	MF 70A4 740	W486324H01	フェルト	Felt for hook shaft	1										
191	M9 1251 030	W500190H01	特殊ネジ 3/16(32)×6.7	Special screw 3/16(32)×6.7	1										
192	M9 1101 002	W500194H01	平ネジ 11/64(40)×4.0	Set screw 11/64(40)×4.0	2										
193	MF 10A0 120	W218864H01	カマ (HSL-BS1J/KHS-12SM)	Rotating hook (HSL-BS1J/KHS-12SM)	1										
	MF 22B0 120	P 975010X01	カマ (HSL-AN/KHS 12R)	Rotating hook (HSL-AN/KHS-12R)	1										
194	MF 25B0 120	P 975005X02	カマ (HSM-A/KHS-20RM2)	Rotating hook (HSM-A/KHS-20RM2)	1										
	MF 10A0 123	W462632H01	ボビン (標準)	Bobbin	1										
195	MF 25B0 123	W470215H01	ボビン (2倍ガマ)	Bobbin	1										
	MF 10E0 125	P 976009X01	ボビンケース (標準)	Bobbin case	1										
196	MF 25E0 125	W473391H01	ボビンケース (2倍ガマ)	Bobbin case	1										
	M9 1118 002	B 509061H01	平ネジ 11/64(40)×10	Screw 11 64(40)×10	1										
197	MF 10A0 229	W462633H01	内ガマ止メ (標準)	Rotating hook positioner	1										
	MF 17B0 229	W470246H01	内ガマ止メ (極厚)	Rotating hook positioner	1										
	MF 20A0 229	W468837H01	内ガマ止メ (2倍ガマ)	Rotating hook positioner	1										

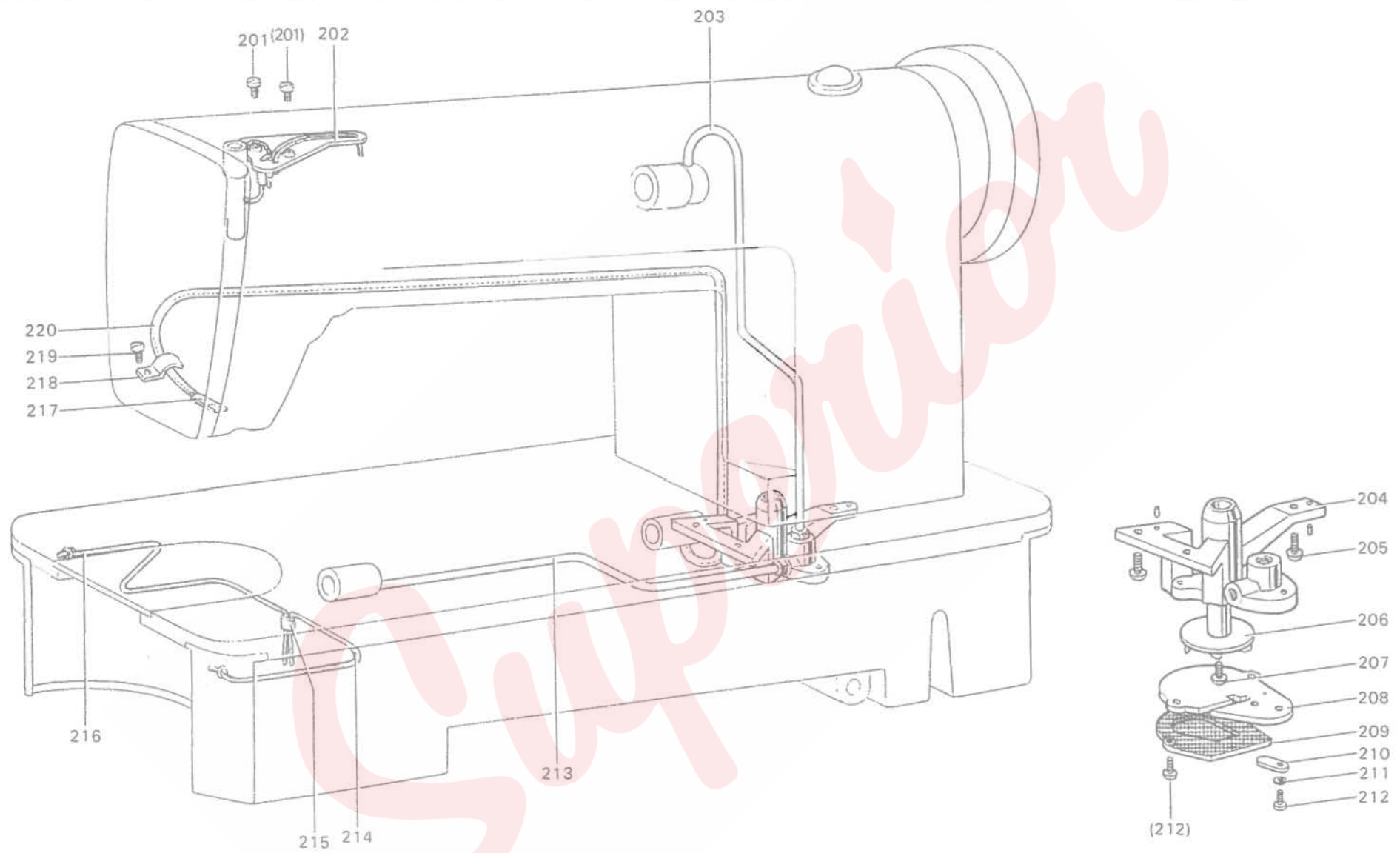

給油関係

LUBRICATION MECHANISM

Fig. No.	部品コード Parts. No.	資材コード Ref. No.	品名	Description	使用 個数 Amt Req	共通部品 Common Parts							
						DB130G10	DB130G11	DB130G12.7	DB130G22	DB130L10	DB130L12.7	DB130L22	
201	M9 0939 002	W464016H02	平ネン 9 64(40)×11	Screw 9/64(40)×11	2								
202	MF 80A0 601	W486313G01	取付板 紐付キ組	Oil braid fitting plate	1								
203	MF 80A1 688	W476410G02	ハイフ (上輪給油組)	Oil pipe for arm shaft	1								
204	MF 80A0 783	W346046H01	ナンプケース	Oil pump (body)	1								
205	M9 1103 004	W467868H01	フラマイネシ 11 64(40)×13	Screw 11 64(40)×13	3								
206	MF 10A0 685	W470288H01	羽根車	Oil pump impeller	1								
207	M9 0810 002	W501133H01	平ネン 1 8(44)×8	Screw 1 8(44)×8	1								
208	MF 10A0 601	W461088H01	取付板	Oil pump fitting plate	1								
209	MF 10E0 337	W502363G01	金網	Oil pump screen	1								
210	MF 10A1 742	W470250H01	蓋	Oil adjusting plate	1								
211	M9 0402 053	W500297H01	ハネ座全	Sprng washer	1								
212	M9 0801 004	W467881H01	フラマイネシ 1 8(44)×13	Screw 1 8(44)×13	3								
213	MF 80A2 688	W461745G02	ハイフ (下輪給油組)	Oil pipe for hook shaft	1								
214	MF 10E2 148	W444138H01	油紐 (上下送り腕 φ2.5×240)	Oil braid for feed lifting mechanism	1								
215	MF 80A0 780	W501092H01	ホルター	Holder for oil braid	1								
216	MF 10E2 148	W462982H01	油紐 (水平送り腕 φ2.5×330)	Oil braid for feed rock mechanism	1								
217	MF 10A0 740	W502394H01	フェルト	Felt pouch for return oil filter	1								
218	MF 70A0 689	W484833H01	ホルター	Holder for oil pipe	1								
219	M9 1107 002	W500092H01	平ネシ 11 64(40)×5.5	Screw 11 64(40)×5.5	1								
220	MF 20A0 731	W484209H03	ビニールハイフ	Oil return pipe	1								

ACCESSORY BOX & ITS ACCESSORIES

DB-130G

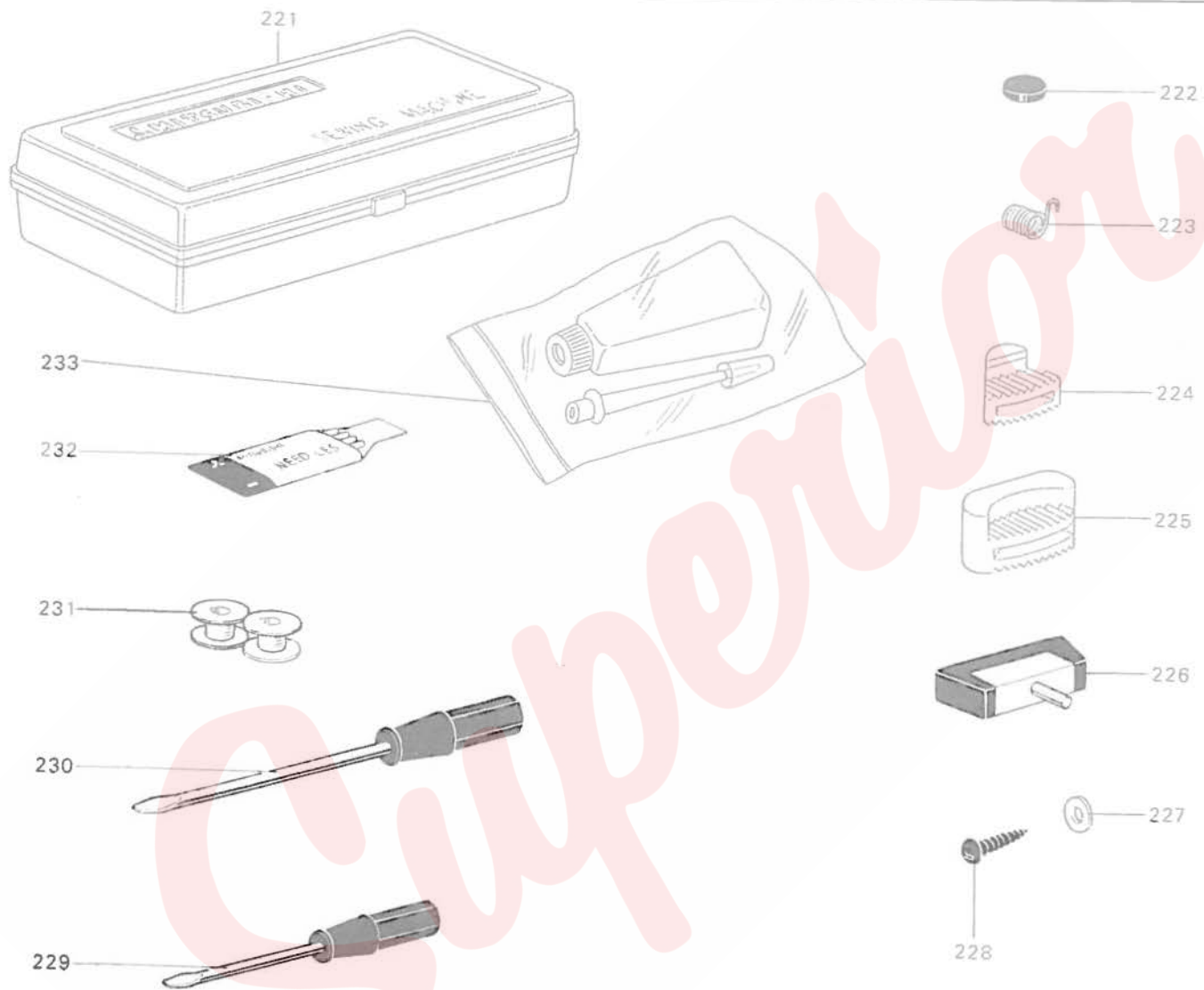

付属品箱関係

ACCESSORY BOX & ITS ACCESSRIES

Fig. No.	部品コード Parts No	資材コード Ref No.	部 品 名	Description	使用 個数 Amt Req	共通部品 Common Parts								
						DB130G10	DB130G11	DB130G12	DB130G20	DB130E10	DB130E11	DB131127	DB131128	
221	MF 60A0 749	P 833000X01	付 属 品 箱	Accessory box	1									
222	M9 0701 099	P 463000X01	OP-S 磁石	Magnet block for reservoir	1									
223	MF 80A0 187	W486346H01	糸 取 リ バ ネ (標準)	Thread take-up spring	1									
	MF 83A0 187	W486346H02	糸 取 リ バ ネ (厚物)	Thread take-up spring	1									
224	MF 70A1 419	W476426H02	防 振 コ ム (小)	Vibration preventing rubber (small)	2									
225	MF 70A0 419	W476425H02	防 振 コ ム (大)	Vibration preventing rubber (large)	2									
226	MF 70E0 418	W481678G02	ゴ ム ヒ ン シ 組	Table hinge with rubber cushion	2									
227	M9 0607 050	S 562131H04	座 全 6	Washer for bobbin winder	2									
228	M9 0401 041	S 519132H01	丸 木 ネ シ 4.5×20	Screw for bobbin winder	2									
229	MB 02A1 608	P 842002X01	ネ ン 回 シ (小)	Screw driver (small)	1									
230	MB 02A0 608	P 842003X01	ネ ン 回 シ (中)	Screw driver (middle)	1									
231	MF 10A0 123	W462632H01	ホ ビ ン (標準)	Bobbin	4									
	MF 25B0 123	W470215H01	ホ ビ ン (2倍ガマ)	Bobbin	4									
232	MF 70A0 128	S 970010H01	ミ シ ン 針 DB×1 2=14	Needle DB×1 2=14	4									
	MF 21D0 128	S 970001H01	ミ シ ン 針 DA×1=11	Needle DA×1=11	4									
	MF 83A0 128	S 970002H03	ミ シ ン 針 DB×1=22	Needle DB×1=22	4									
233	MF 80A0 137	P 831002X01	油 添 シ	Oil with oiler	1									

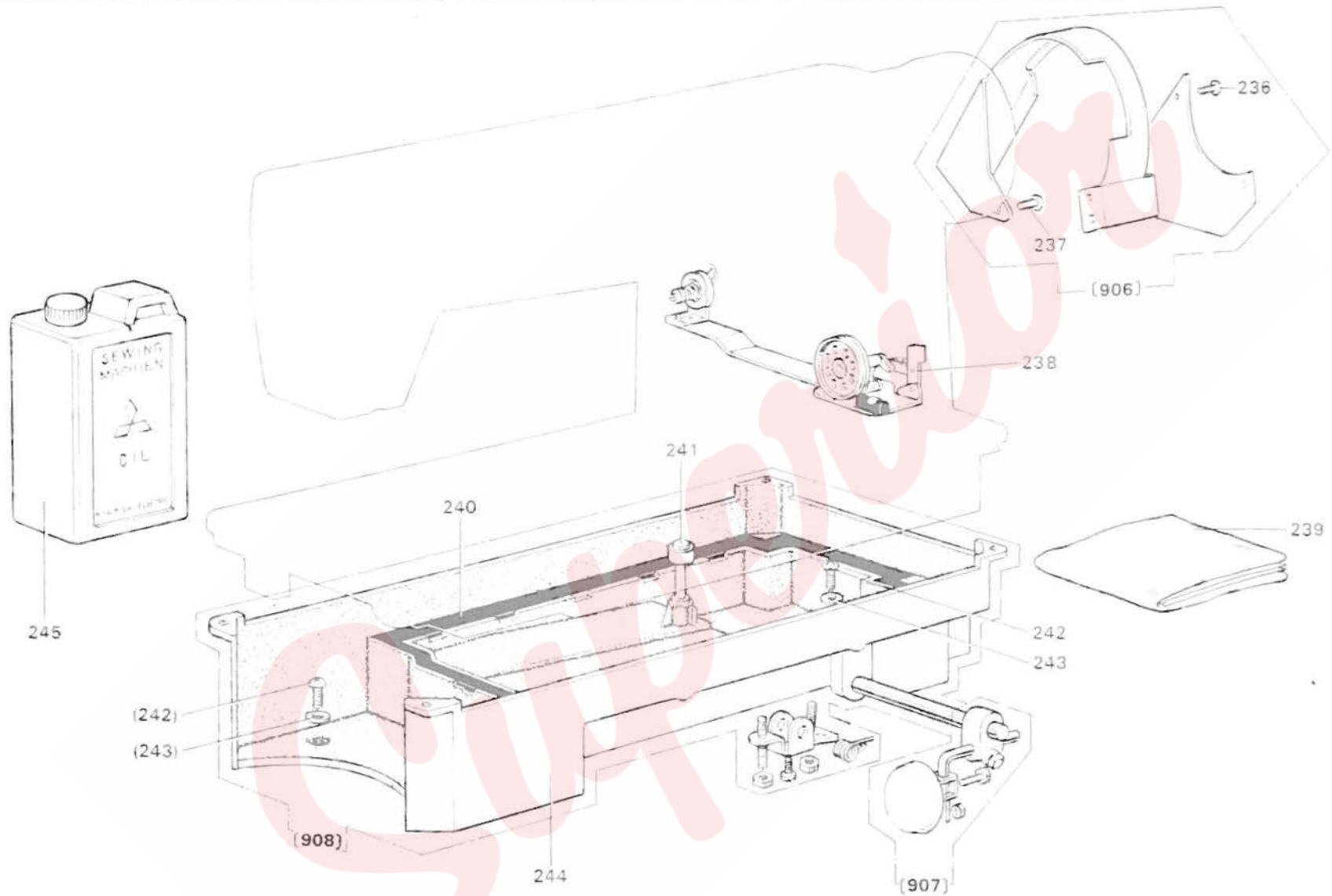

油槽、ソノ他付属品関係

OIL RESERVOIR & OTHER ACCESSORIES

Fig No.	部品コード Parts No	資材コード Ref. No.	部 品 名	Description	使用 個数 Amt Req	共通部品 Common Parts									
						DI-130G-10	DB-130G-11	DB-130G-12-7	DB-130G-22	DB-130E-10	DB-130E-11	DB-130E-12-7	DB-130E-22		
236	M9 1101 004	W466810H01	ブラマイネン 11/64(40)×8	Screw 11/64(40)×8	3										
237	M9 1506 004	W467868H02	ブラマイネン 15/64(28)×8	Screw 11/64(40)×8	3										
906	MF 20E0 776	W338204G01	ベルトカバー (組)(BE-2)	Belt cover complete (BE-2)	1										
	MF 25E0 776	W339679G01	ベルトカバー (組)(BE-11)	Belt cover complete (BE-11)	1										
238	MF 20E0 190	P 992002X01	糸巻仕掛組	Bobbin winder complete	1										
	MF 25E0 190	P 992008X01	糸巻仕掛組 (2倍カマ)	Bobbin winder complete	1										
239	MF 60A0 734	W220627H02	ビニールカバー	Vinyl covor	1										
240	MF 20A2 691	W471440H02	カスケット (小) (油槽)	Gasket for oil reservoir (small)	1										
	MF 20A3 691	W471441H02	カスケット (大) (油槽)	Gasket for oil reservoir (large)	1										
241	MF 70A0 578	W481685H01	膝上ケビン	Knee lifter lifting rod	1										
242	M9 2002 002	W486334H01	平ネシ 5/16(28)×10	Oil drain screw 5/16(28)×10	2										
243	M9 7001 052	W470200H01	特殊座全	Washer	2										
907	MF 40E0 727	W341682G02	膝上ケ仕掛組	Knee lifter complete											
244	MF 80A0 139	P 997000X04	油槽	Oil reservoir	2										
908	MF 80E0 139	W486352G01	油槽組	Oil reservoir complete	1										
245	MF 10E0 149	W227466H01	油缶	Oil can	1										

Superior

未来を開発する
三菱電機

Superior